

420 SERIES

GREENHOUSES 420 SERIES

From start to finish, our team will be your best asset.



BRIGHTER
BY DESIGN





420 SERIES, STRENGTH & LUMINOSITY COMBINED A SMART ENGINEERING

Harnois is a family business, established for more than 50 years. The third generation now leads a dedicated team of over 150 employees who contribute to design, engineer, manufacture, sell and install high quality greenhouse structures and state of the art equipment around the world.

The secret behind Harnois' engineering innovations relies on close collaboration between its engineers and an experienced team of horticultural experts. Together, we create specific solutions for each project, balancing the requirements of the projected crop, the climate constraints of the site and the financial expectations of the owner.

Dedicated to innovation and continuous improvement, Harnois stands alone with greenhouses that are brighter through clever design, with streamlined structures and an unrelenting commitment to quality, durability and long term performance of its product.

Renowned around the world for its expertise and customer service, Harnois is the number one choice of top growers facing the challenges of today's **cannabis culture** and lead the way to new ways of growing in a variety of climates.

Light is essential to life and critical to cannabis plant production. Optimizing this available light within a greenhouse structure is the founding principle behind Harnois' engineering.

With the 420 Series, this science has reached new heights and focuses on the imperatives of three key areas:

- Improved structural strength, while keeping the structure as streamlined as possible;
- Use of graded, high gauge steel and oval tubing for the arches;
- An improved gothic geometry.

The 420 Series' smart engineering benefits the grower in many ways:

- Enhanced light penetration;
- Impressive air volume, especially above gutter level;
- Intuitive climate control and improved climate stability at crop level;
- Superior condensation control and effective drip prevention;
- Roof shape that facilitates covering installation.



LUMINOSA 420

Gutter connected greenhouse

This model is our brightest and most popular, with over 500 acres sold to date. Designed to offer the best crop growing conditions, this high tech greenhouse combines smart engineering and agronomic know-how. It comes in two versions: one optimized for warm/snowless climates and the other for Nordic/temperate climates.

Width*	36'
Height under gutter B	From 12' to 24'-6"
Inside clearance (with tube) C	B + 1 ½"
Height of glabe A	10'-2 ½"
Dimensions of arch tubing	2 ¾" x 4 5/16"

* Available in different widths : 21.4', 26.3', 30' and 31.6'.

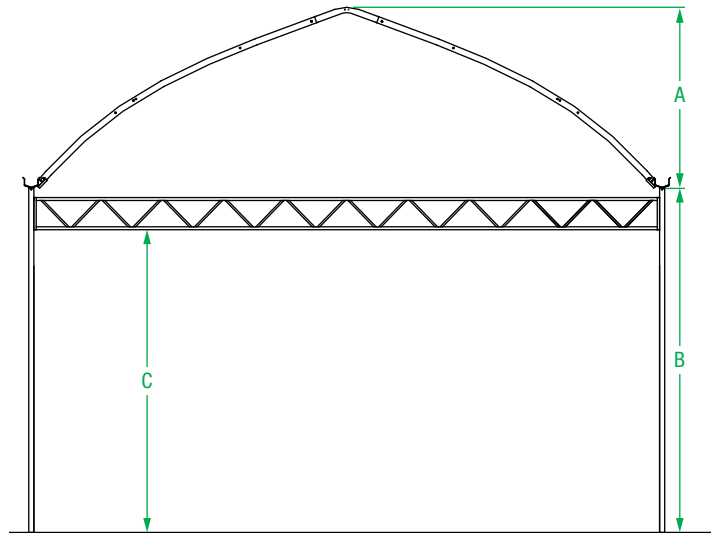

OVALTECH 420

Ground-to-Ground greenhouse

The popularity of the Ovaltech testament to its versatility and durability. It has become the standard in terms of wind and snow resistance. Its efficient design allows for abundant light, which, in turn, promotes uniform crop growth across the greenhouse. Furthermore, it is engineered to enhance natural ventilation, creating a favorable environment for healthy crops while saving energy.

Width*	42'
Arch spacing	6'
Inside clearance A	10'
Total height B	17'-4"
Tubing dimensions	4 5/16"

* Available in different widths from 20' to 42'.

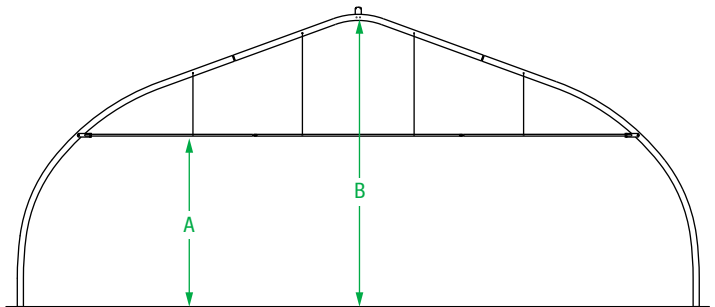

AR 420

Indoor Warehouse

The AR series is a custom engineering solution which is designed to address very specific industrial, commercial and agricultural standards. Our specialized engineers design custom structures for every project. These permanent buildings bring together the innovative MegaDome® design and all of the benefits of conventional buildings.

Truss thickness : according to project needs			
Width	Height under gutter A	Total height B	Width C
60' to 100'	10' to 16'	30' to 45'	2' to 4'

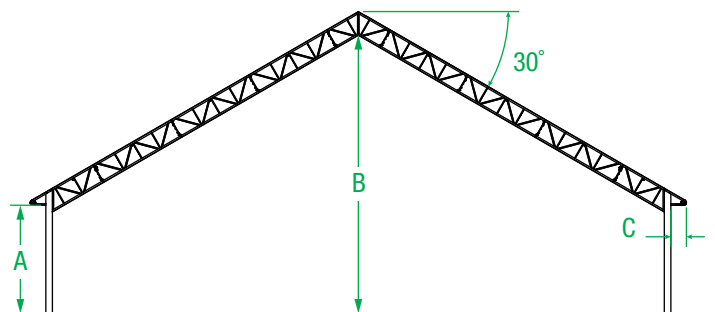

COVERINGS

The choice of covering can have a tremendous impact on the luminosity levels provided to the cannabis crops. Harnois selects only the most evolved roof greenhouse coverings, based on translucency and durability.

Our covers offer a variety different options with specific properties such as light diffusion, anti-drip, thermal or sulphur resistance.

- Rigid polycarbonate panels for sidewall, end wall and roof. It offers excellent durability, insulation and security for cannabis growers.
- Rigid metal or polycarbonate panels on sidewall and end wall option to meet local building code and protection from theft and severe weather.
- Roof membrane for the AR 420.

The three choices of covering comply with cannabis industry standards of safety and security.



Sheet metal.



Polycarbonate.



Roof membrane (AR 420).

A COMPLETE RANGE OF GREENHOUSE EQUIPMENT & ACCESSORIES

Harnois offers a wide variety of quality greenhouse equipment to accessorize your greenhouse operation, from basic systems to the most sophisticated ones. They integrate seamlessly with the greenhouse installation, offering you the possibility of sourcing a complete growing system from a single supplier. Our experts will lead you through our equipment catalog to find a custom solution that meets your budget parameters.



Irrigation and fertilization injectors



Benches



Heating systems



Cooling systems and dehumidification



Fans



Growing lamps



Hot Water heating



Climate Control



Automated black out and shade systems



Roof and lateral ventilation systems



Odor control



Security systems

The 420 Series is a suite of greenhouses and engineered warehouse buildings which are designed to respond to the needs of any cannabis growers or investors.

Ready to move to greenhouse cultivation? Are you new to greenhouse cultivation? We can meet your structure needs for all types of crop environment, or greenhouse models you are looking for.

AN INTEGRATED SERVICE

We know time is precious. That is why Harnois makes a cannabis grower's life easy by supplying a complete range of value-added services that go hand-in-hand with its quality greenhouses and equipment. The sales, installation and technical support teams work together to hasten the project's start-up and help cannabis growers quickly get a good grip on new equipment.

KNOWLEDGEABLE TEAM

Responsiveness and expertise are the backbone of our customer service, positioning us as trusted advisors to cannabis growers. Through our dedicated team and external consulting experts, customers feel supported and prepared to successfully tackle the challenges of today's cannabis agriculture, while meeting their business objectives, in any climate. Whether you are a newcomer to the cannabis agriculture or an existing grower looking to improve the profitability of their production, our 420 Series Greenhouse range can be customized to perfectly match the needs of your operation and your expectations.



Our services offer you a complete solution under one roof

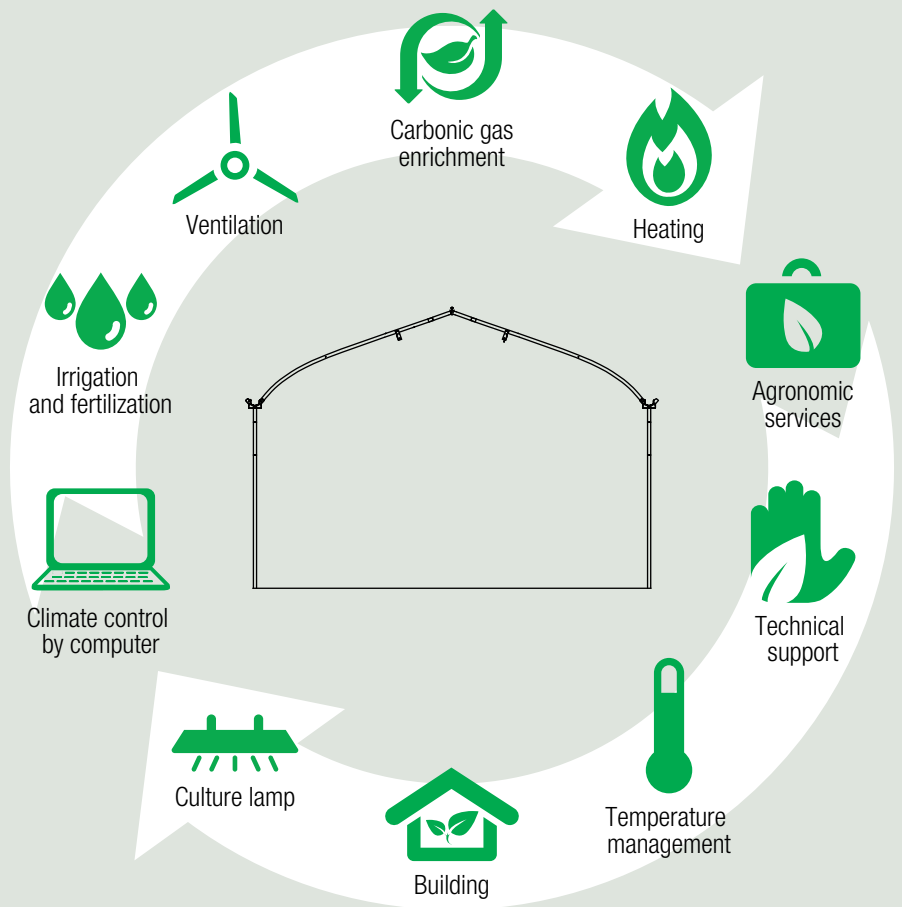

Harnois Greenhouses is a division of Industries Harnois inc., an established leader in the design and manufacturing of innovative steel structures that meet the financial operational needs of our clients.

For more information, contact your sale representative.

1044 Principale, Saint-Thomas (Quebec) Canada J0K 3L0

Toll free : 1 888 427-6647 Fax : 450 756-8389

Information provided in this document is subject to change without notice.



harnois.com