

LUMINOSA

GUTTER CONNECTED GREENHOUSE

From start to finish, our team will be your best asset.



BRIGHTER
BY DESIGN



STRENGTH & LUMINOSITY THROUGH SMART ENGINEERING LUMINOSA SERIES 8-9-11

Light. It's an essential ingredient to life and certainly to plant production. Optimizing this available light within a greenhouse structure is the founding principle behind Harnois' engineering.

With the Luminosa Series 8-9-11, this science has reached new heights and balances out the imperatives of three key areas:

- Adequate structural strength, while keeping the structure as streamlined as possible;
- Use of graded, high gauge steel and oval tubing for the arches;
- An improved gothic geometry.

The Luminosa's smart engineering brings many benefits for the grower:

- Enhanced light penetration;
- Impressive air volume, especially above gutter level;
- Simplified climate control and improved climate stability at crop level;
- Superior control of condensation and effective dripping prevention with a ridge angle of 45°;
- Roof shape that facilitates poly film installation.

Harnois is a family business, established since 1965. The third generation is now leading a large team of over 150 employees in designing, manufacturing, selling and installing quality greenhouse structures and equipment across 6 continents.

Dedicated to innovation and continuous improvement, Harnois stands apart with greenhouses that are brighter through clever design, with streamlined structures and a firm commitment to quality, durability and long term performance of its product.

Renowned around the world for its expertise and customer service, Harnois is the choice of top growers and institutions, to help them face the challenges of today's agriculture and lead the way to a new kind of growing, under all kinds of climates.



ENGINEERING FOR AGRONOMIC EFFICIENCY

The strength of Harnois' engineering relies on close collaboration between its engineers and an experienced team of horticultural experts. Together, they create specific solutions for each project, balancing the requirements of the projected crop, the climate constraints of the site and the financial expectations of the owner.

In close to 50 years of business, this team has acquired a solid experience in high technology greenhouse management. They readily share their knowledge with customers, facilitating the mastering of some of the most advanced growing techniques every time it is possible.



Foundations.

The Luminosa requires concrete foundations that can be either piers or walls, whatever will make the operations more efficient. All of our greenhouses can come with engineer's sealed plans, facilitating the building permit process.

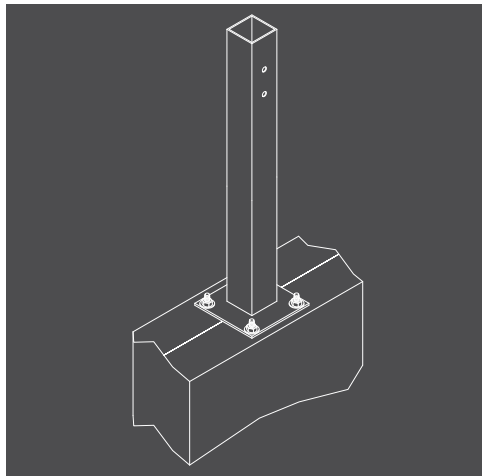

Anchor plates for concrete: ideal for installations on existing or newly poured concrete slab.

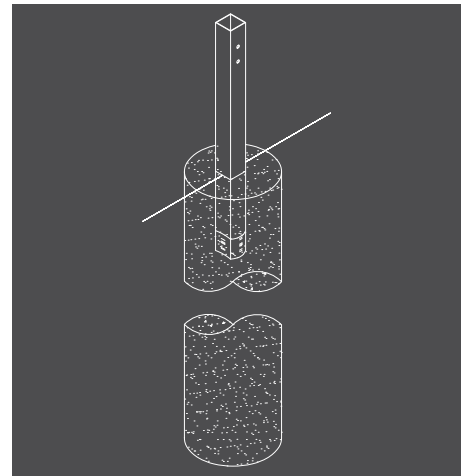

Concrete piers

The arches of the Luminosa are made from oval steel tubing, whose geometry has proven benefits compared to round or rectangular tubing in modern greenhouse engineering. The oval tube can be up to 4 times stronger than comparable tubing.

- Made of certified, graded galvanized steel with a minimum resistance of 50 ksi, which is **52% stronger than commercial steel tubing commonly used.**
- The oval's rounded shape offers a smooth, edge-free surface upon which it is easy to stretch poly films, increasing their life span.
- A clear, organic coating seals the galvanization treatment and prevents it from staining the covering.
- Metric spacing is also available for vine crops grown under European's best practices.

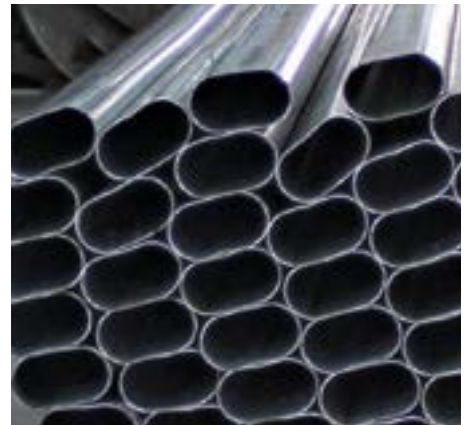

The columns of the Luminosa are designed in two parts and their precise assembly is done when the expanded bottom of the post is tightly fitted over the anchor. This unique assembly ensures the structural integrity of the greenhouse and allows for greater load capacity.

- Made from graded, high gauge square or rectangular galvanized steel tubing.
- One size of tubing is used: 3.5" square. The structural capacity required for the locality where the greenhouses will be erected will dictate which tube is selected;
- Post spacing will also be adjusted, as required, to find the right balance between the required resistance and the lighter structure possible.

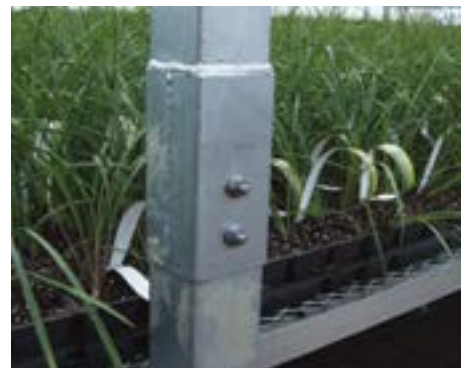

The gutters of the Luminosa are laid on top of one-piece, modern gutter support, which eases installation and confers superior resistance to the assembly.

- Gutters are structural and play an active role in effectively transferring the snow loads across all the greenhouse's posts;
- Narrower, they maintain efficient water evacuation, while minimizing cast shadow and thermal bridges inside the greenhouse.



THE LUMINOSA is available in different widths. Models 21'-4", 26'-3", 30', 31'-6" and 36' are optimized for vine crops, laid out according to European (metric) best practices, with rows spaced every 1.6 or 1.8 meters. These models are the best choice for tomatoes, cucumbers or peppers as they optimize the greenhouse space and enhance the profitability of the operation.

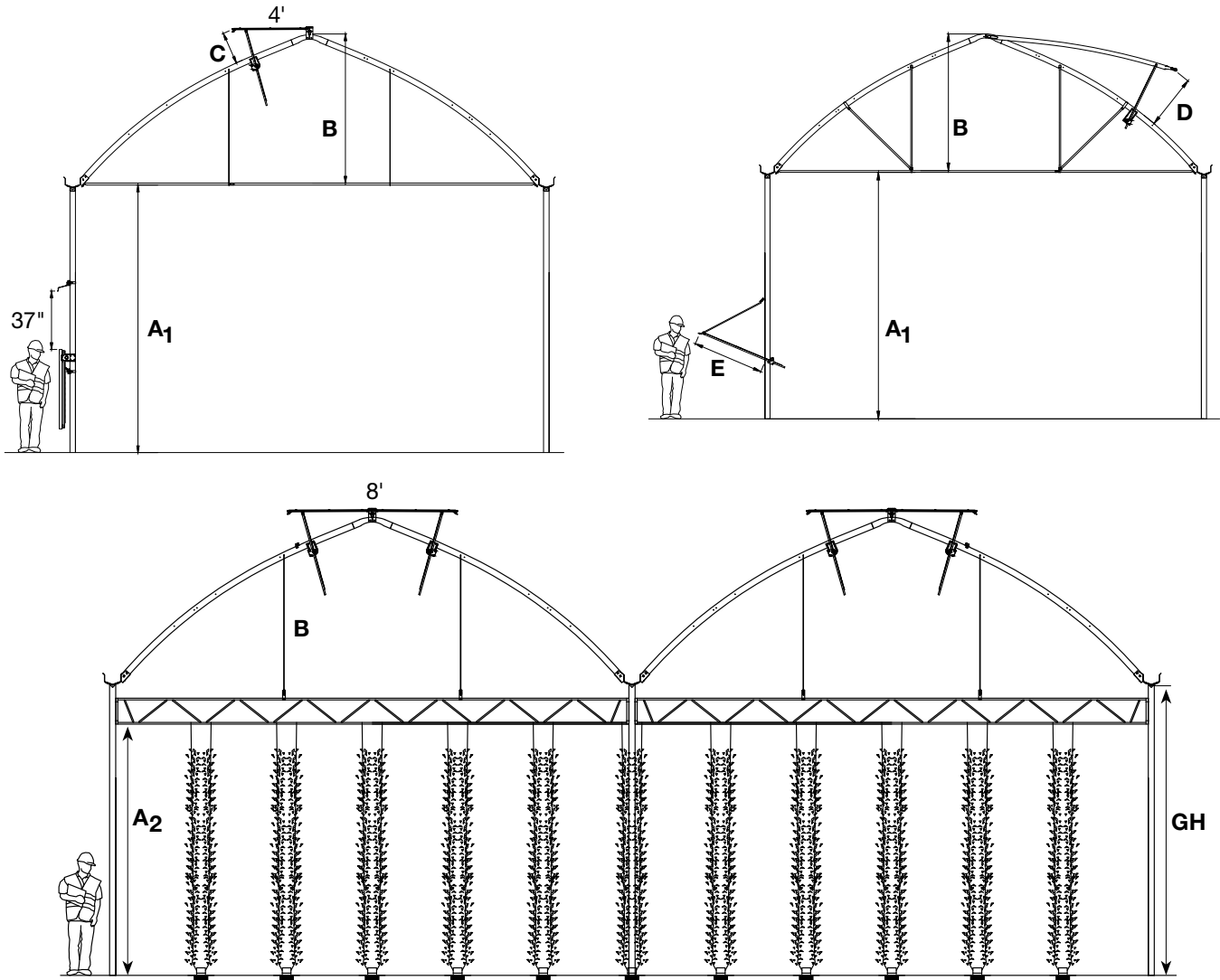

Models	Series 8				Series 9			Series 11
Width	21'-4"	24'	25'	26'-3"	28'	30'	31'-6"	36'
Height under gutter GH	12' 14' 16' 18' 6m							
Inside clearance (with tube) A1	arch $1\text{-}\frac{5}{8}\text{''} \times 2\text{-}\frac{3}{4}\text{''} = \text{GH} + 3\text{''}$							
	arch $2\text{''} \times 3\text{-}\frac{9}{16}\text{''} = \text{GH} + 1\text{-}\frac{5}{8}\text{''}$							arch $2\text{''} \times 3\text{-}\frac{9}{16}\text{''} = \text{GH} + 1\text{-}\frac{5}{8}\text{''}$
	arch $2\text{-}\frac{3}{4}\text{''} \times 4\text{-}\frac{5}{16}\text{''} = \text{GH} + 1\text{-}\frac{3}{8}\text{''}$							arch $2\text{-}\frac{3}{4}\text{''} \times 4\text{-}\frac{5}{16}\text{''} = \text{GH} + 1\text{-}\frac{3}{8}\text{''}$
Inside clearance (with truss) A2	GH - 23" (15" truss)							GH - 29-3/4" (22" truss)
	GH - 27-7/16" (20" truss)							GH - 38-3/4" (31" truss)
Height of gable B	7'-8-1/2"	8'-3-1/2"	8'-6-1/4"	8'-9"	9'-3-1/2"	9'-8-1/2"	10'	10'-3-5/8"
Dimension of arch tubing	1-5/8" x 2-3/4" or 2" x 3-9/16" or 2-3/4" x 4-5/16"							2-3/4" x 4-5/16"
Dimension of vents								
roof vent (opening) C	36"	35"	34-1/2"					
Simple 4', double 8'								
Mid-roof vent D	38-1/2"	37-5/8"	37-3/8"	50-5/8"	49-1/4"	48-3/4"	48-1/2"	60-3/8"
Side panel (opening) E	39-1/2"							
Guillotine panel (opening) F	37"							

ROOF VENTILATION

As in all Harnois greenhouses, the Luminosa is designed to enhance natural ventilation and create superior ventilation dynamics. Several ventilation options are available, from the popular mid-roof vent to lateral openings and single or double roof vents. Harnois' experts will guide you through the range to find the perfect combination to create the ideal micro climate for the crop. Aluminum extrusions, exclusive to Harnois, equip all the vents to provide adequate weather sealing and all are insect screen ready.



Single panel



Mid-roof panel



Polycarbonate

LATERAL VENTILATION

Lateral ventilation is essential to efficient roof ventilation. By providing a fresh air intake, it creates conditions that are more conducive to an active chimney effect than roof vents alone. It prevents hot spots from occurring inside the greenhouse, which could complicate crop management across the range.



Full side roll-up



Partial side roll-up



Side roll-up with polycarbonate wall



Mechanical ventilation (cooling pad)



Side vents rack and pinion system

COVERING

The right greenhouse structure can have a tremendous impact on the luminosity levels provided to the crops. The choice of covering is just as important. Harnois selects only the most evolved greenhouse coverings, based on translucency and durability. Its covering range includes many options with specific properties such as light diffusion, anti-drip, thermal or sulphur resistance.



Double polyethylene films 7.2 mil: this option includes the blower and connections.



8 mm, double wall polycarbonate panels: this rigid covering offers excellent durability and good insulation.

A COMPLETE RANGE OF GREENHOUSE EQUIPMENT

Harnois offers a large variety of quality greenhouse equipment to accessorize your greenhouse operation, from the basic systems to the most sophisticated ones. They all integrate seamlessly with the greenhouse installation, offering you the possibility of sourcing a complete growing system from a single supplier. Our experts will lead you through our equipment catalog to find what you need at the price you want.



Aquaboom



Irrigation



MegaDome® for Biomass Storage



Benches



Heating



Hot Water Heating



Thermal / shading and black-out screens



Insect Screen



Lamps



Climate Control



Ventilation

AN INTEGRATED SERVICE

We know time is precious. That is why Harnois makes a grower's life easy by supplying a complete range of value-added services that go hand-in-hand with its quality greenhouses and equipment. The sales, installation and technical support teams work together to hasten the project's start-up and help growers quickly get a good grip on new equipment.

This turnkey service also ensure Harnois' can take over the full responsibility of the project, if the customer so desires. This limits the number of players on the construction site and frees the grower for more important tasks. Once the project is completed and fully launched, Harnois' support remains easily accessible. Our teams understand the reality of greenhouse growers and are sensitive to the importance of acting quickly to solve problems. They will do what it takes to minimize downtime and have the operation back on track as soon as possible.

With Harnois, you are in good hands.



BRIGHTER
BY DESIGN

Harnois Industries Inc.

1044 Principale, Saint-Thomas, Quebec, Canada J0K 3L0

Tel.: 450.756.1041 Toll free: 1.888.427.6647

HARNOIS.COM | info@harnois.com

