

TUNNELPRO



# TUNNELS GREENHOUSE

*From start to finish,* our team will be your best asset.



BRIGHTER  
BY DESIGN



The **CONNECTED TUNNEL SOLUTION** to cover large crop areas affordably.

## ACHIEVING THE BENEFITS OF GROWING UNDER PROTECTION

Growers are increasingly turning to high tunnels to protect large crop areas from unpredictable weather conditions. With TunnelPro, you can:

- Add weeks to the crop's regular production schedule: start early and extend the growing season.
- Manage the climate actively with proper venting and protection.
- Save on labor with easy to operate roll-up vents.
- Improve crop yield and quality by shielding the crop from the elements.
- Use fewer chemicals and facilitate their application when they are needed.
- Ideal for pick-your-own operations.

## INCREASED PROFITABILITY

Increased productivity and lower operating costs influence crop profitability. Studies have demonstrated that four major factors influence profitability of growing with TunnelPro:

- Increased plant size: plants grown under tunnels are shown to be larger and sturdier, reaching market size faster than field grown.
- Increased number of fruits/flowers per plant.
- Increased turnaround: growers typically get 1-2 additional crop rotations in a given growing season.
- Higher selling price for being earlier and later on the market.

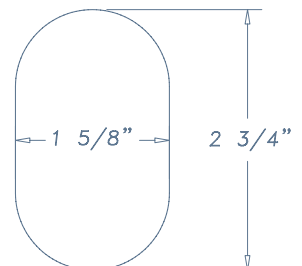

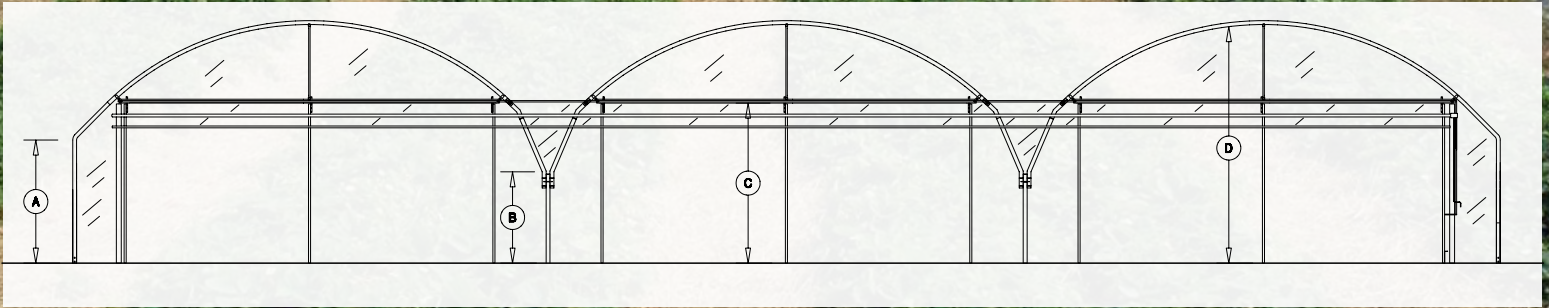

## SPECIFICATIONS

TunnelPro is designed by a greenhouse manufacturer combining 45 years of engineering expertise and horticultural knowledge. Each structure is manufactured using pregalvanized, oval tubing made of structural steel for years of corrosion protection. Components are swaged, curved and pre-drilled before reaching the construction site, for fast and easy assembly. Hand cranks have a built-in stop mechanism for work crew safety.

Width	28'		30'	31'	
	High	Low	High	High	Low
Arch spacing	10'	10'	10'	10'	12'
Side vent height (A)	84"	60"	84"	84"	60"
Leg height (B)	63"	39"	63"	63"	39"
Clearance (inside) (C)	115"	91"	126"	132"	108"
Total Height (D)	173"	149"	185"	191"	167"

Screw-type anchors are installed below frost to ensure stability and provide superior uplift resistance.

Covering is secured with durable 1" wide, UV stabilized nylon straps that are stronger than rope and will not cut through the poly.



## OPTIONS

TunnelPro is offered with several value-added options, to customize the tunnel to the specific crops produced. The unique poly storage kit keeps the plastic film covered when it is not needed. It is also ready to unroll quickly when the need for protection arises, saving time and labor.



Side roll-ups up to 300 ft



42" high roof roll-up, up to 300 ft  
(up to 2 per bay, one on each side)



50-50 curtain door



Full length roll-up on gable end,  
up to 250 ft long



Poly rolled at peak and securely stored



# HARNOIS

BRIGHTER  
BY DESIGN

### Harnois Industries Inc.

1044 Principale, Saint-Thomas, Quebec, Canada J0K 3L0

Tel.: 450.756.1041 Toll free: 1.888.427.6647

Fax: 450.756.8389

**HARNOIS.COM** | info@harnois.com

