



LIGHT AND ENERGY EFFICIENT SOLUTION
for the welfare of your animals



**BRIGHTER
BY DESIGN**



OVER 50 YEARS OF EXPERIENCE DESIGNING AND CONSTRUCTING GREENHOUSES

Since the sale of its first irrigation system in 1958, Industries Harnois has quickly positioned itself as one of the pioneers among the manufacturers of North American steel structures with its vast offer of Greenhouses, MegaDome® buildings and equipment.



We strive to innovate every day. We are constantly pushing the boundaries of engineering to be at the top and remain as leaders in our field.

Thanks to our innovative solutions and our dedicated team, we will continue to be pioneers in this industry.

Over 50 years of experience	Over 20 000 international projects	Over 500 projects delivered each year	2 divisions to better meet the needs of our customers
------------------------------------	---	--	--

TO SIMPLIFY YOUR LIFE, WE OFFER TURNKEY PROJECTS

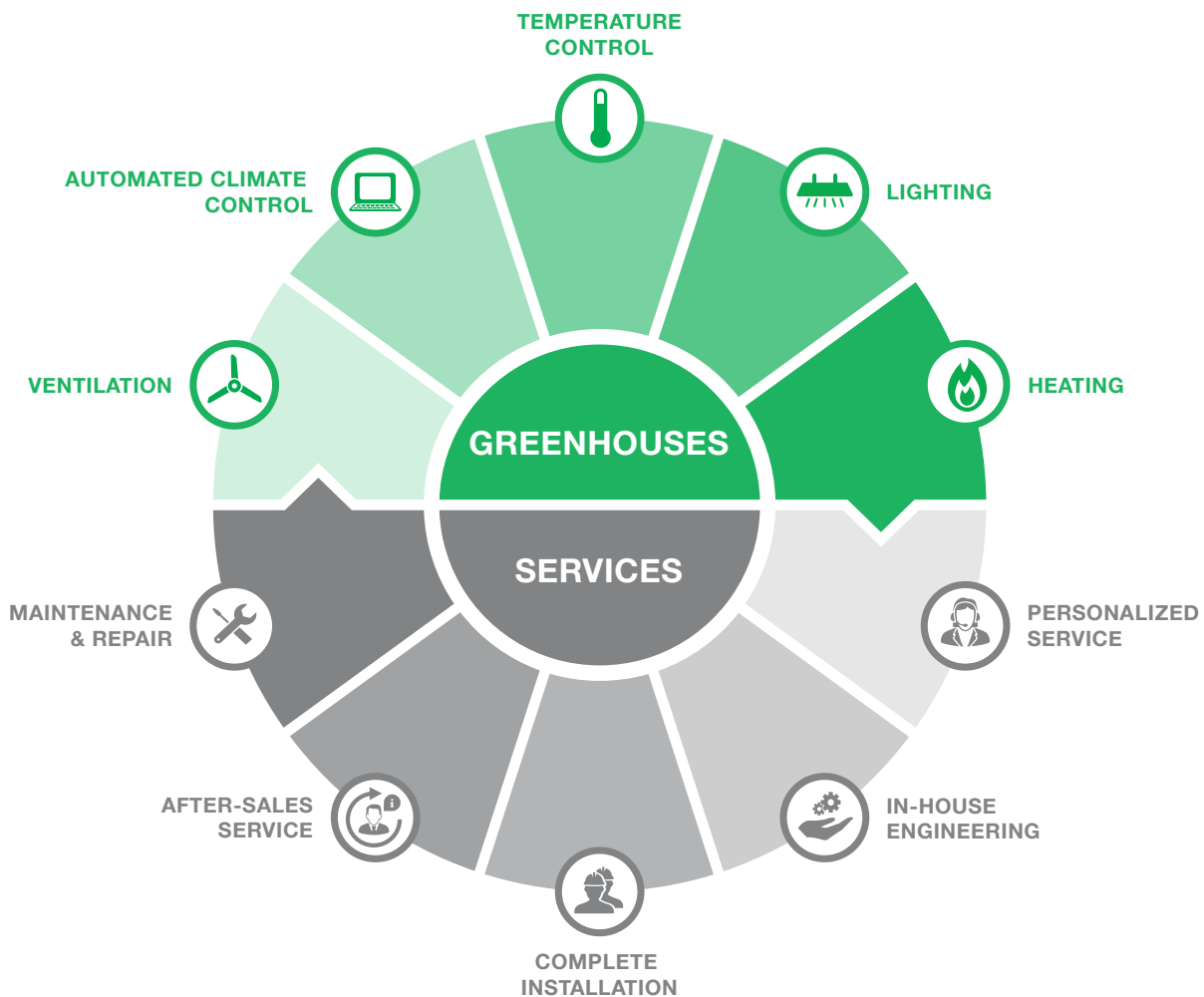



GREENHOUSES FOR ANIMALS

Whether they are gutter connected greenhouses or individual greenhouses, both options offer several advantages to breeders who choose to use a greenhouse rather than a conventional building to protect their animals.

Why choose a greenhouse rather than a conventional building ?

Low acquisition
and operating costs

Much
brighter

Superior
ventilation
and climate control

Environment that promotes
livestock growth and productivity

MULTIPLE USES

Harnois Greenhouses can be used for all types of agricultural breeding projects.

Allows to **protect animals** that are raised in the wild during winter

Meets MAPAQ **farm regulations**

Many available options to **ensure animal welfare**

Meets the needs of **all type of animals**

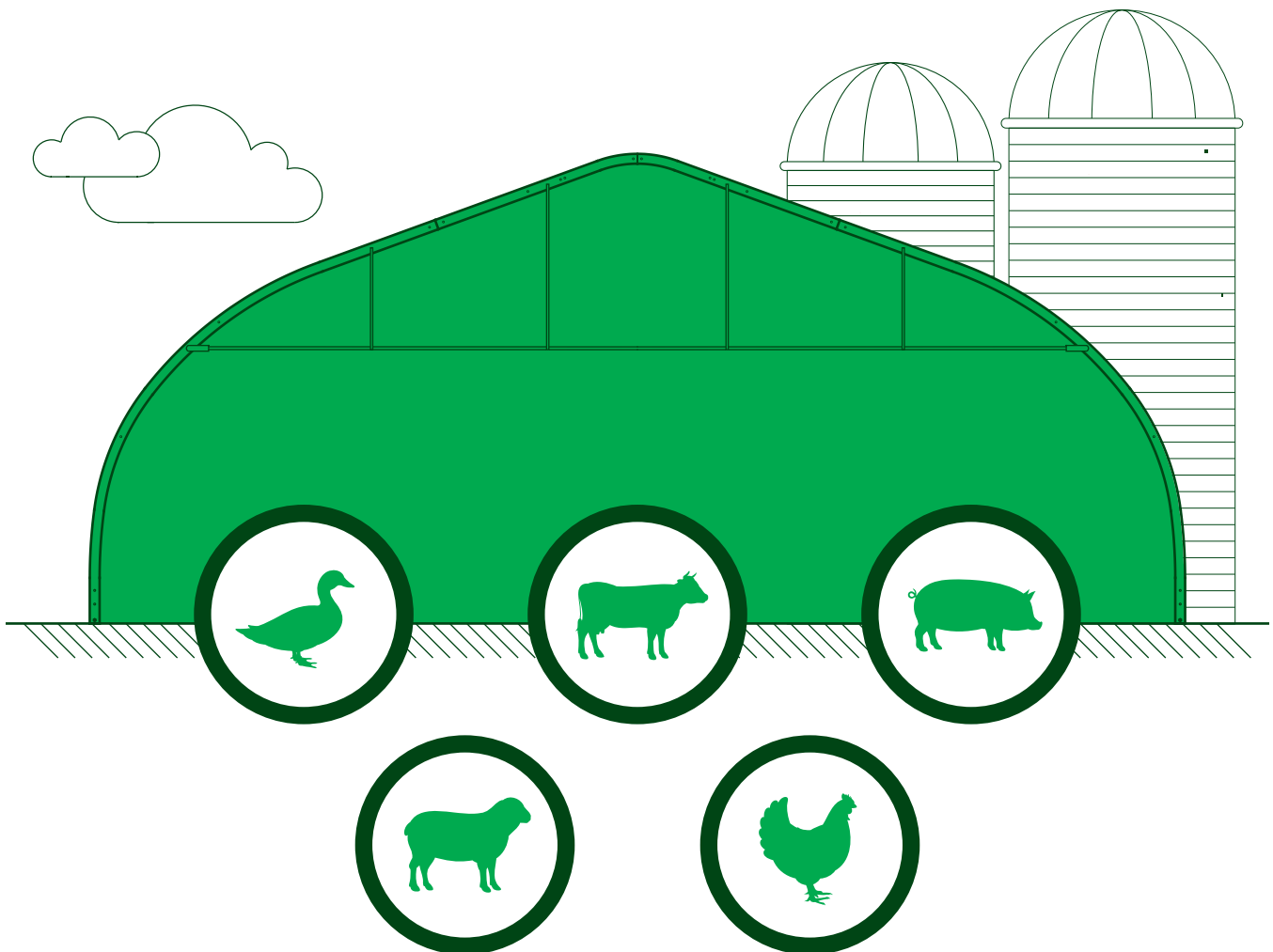

TECHNICAL SPECIFICATIONS

Luminosa™ – Gutter connected greenhouse

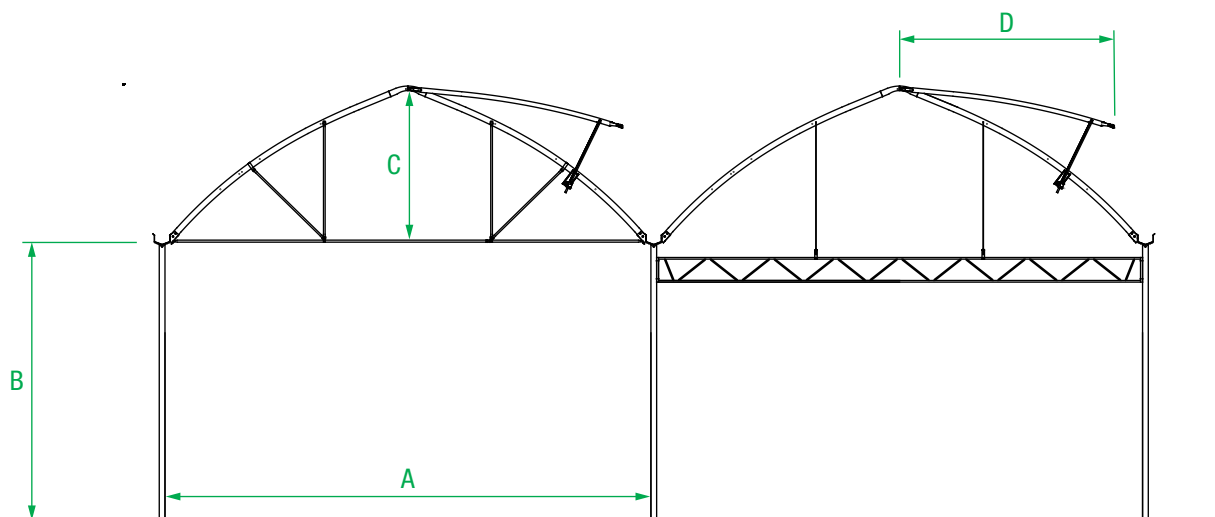

Width A	21'-4"	24'	25'	26'-3"	28'
Height under gutter B	De 16' à 24'-6"				
Height of gable C	7'-1"	7'-7 1/2"	7'-10"	8'-1 1/8"	8'- 7 1/2"
Mid-roof vent D	100 1/2"	117 1/2"	124 1/4"	132"	143"

EQUIPMENT AND OPTIONS

Foundations



Lighting



Heating



Ventilation



Ovaltech™ – Ground to ground greenhouses

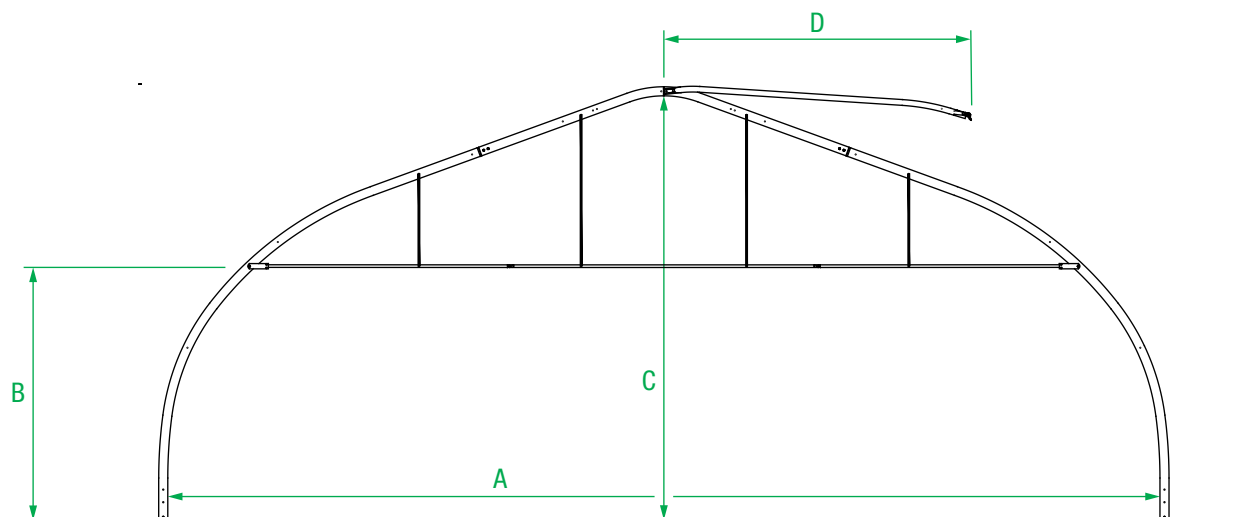

	I		III				IV	
Width A	25'	27'	25'	30'	32'	35'	40'	42'
Height under gutter B	6'-9"		9'	9'-3"		10'		
Height of gable C	11'-1"	11'-4"	14'	14'-10"	15'-1"	15'-7"	17'-4"	
Mid-roof vent D	N/D		125"	137"	156"		N/D	



HIGH QUALITY STRUCTURES, CERTIFIED AND GUARANTEED



Our brands:



Industries Harnois inc.
1044, Principale, Saint-Thomas
(Quebec) Canada J0K 3L0

Toll free : 1 888 427-6647
Fax : 450-756-8389

harnois.com | info@harnois.com